



Myelodysplastic scoring system with flow cytometry

G Detry

B Husson



Les Centres Hospitaliers
A.S.B.L.

Jolimont - Lobbes
Tubize - Nivelles

Myelodysplastic syndroms

- Clonal haematopoietic stem cell disease characterized by dysplasia in one or more of the myeloid cell lines leading to ineffective hematopoiesis and cytopenia(s). WHO 2008
- Morphological examination
 - Dysplasia (>10% in at least one BM lineage)
 - Blast cells % in PB and BM
 - Ringed sideroblasts
- Cytopenia (For more than 4 weeks)
 - Hb <10g/dL
 - Neutropenia <1.500/ μ L
 - Thrombopenia <100.000/ μ L

MDS Classification

	Peripheral blood	Bone marrow
Del(5q)	<ul style="list-style-type: none"> •Anemia •No or rare blast cells without Auer Rod •Normal or elevated platelets count 	<ul style="list-style-type: none"> •Hypolobulated megacaryocytes •Isolated Del(5q) •<5% of blast cells without Auer Rod
Refractory anemia (RA)	<ul style="list-style-type: none"> •Anemia •No or rare blast cells 	<ul style="list-style-type: none"> •Isolated Erythroid Dysplasia •<5% Blast •<15% ring sideroblasts
Refractory anemia with RS (RARS)	<ul style="list-style-type: none"> •Anemia •No or rare blast cells •Not more than 600.000 plt/μL 	<ul style="list-style-type: none"> •Erythroid Dysplasia alone •<5% Blast •>15% ring sideroblasts
Refractory cytopenia with multilineage dysplasia (RCMD)	<ul style="list-style-type: none"> •Cytopenia(s) •No or rare blast cells without Auer Rod •<1000 monocytes 	<ul style="list-style-type: none"> •>10% of dysplasia in at least 2 lineages •<5% of blast cells without Auer Rod
RAEB-1	<ul style="list-style-type: none"> •Cytopenias •<5% of blast cells without Auer Rod •<1000 monocytes 	<ul style="list-style-type: none"> •Unilineage or Multilineage Dysplasia •5-9% of blast cells
RAEB-2	<ul style="list-style-type: none"> •Cytopenias •No or rare blast cells +/- Auer Rod •<1000 monocytes 	<ul style="list-style-type: none"> •Unilineage or Multilineage Dysplasia •10-19% of blast cells
MDS-U (provisory)	<ul style="list-style-type: none"> •Cytopenias •No or rare blast cells without Auer Rod 	<ul style="list-style-type: none"> •Dysplasia in less than 5% of all lineages •Clonal cytogenetic abnormalities suggestive of MDS

Cytomorphology

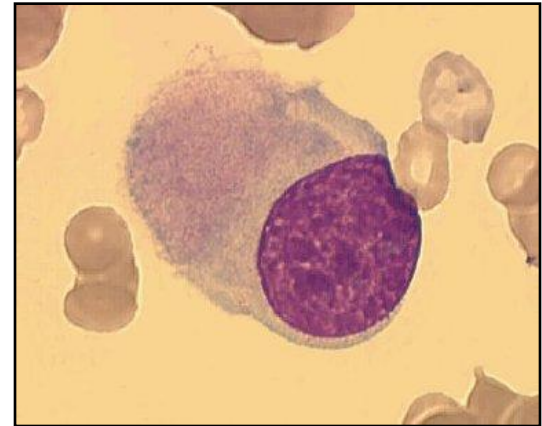
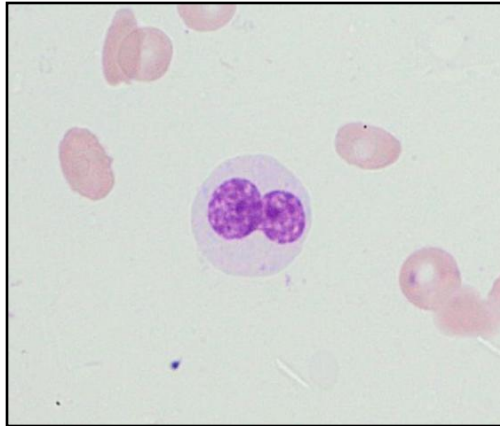
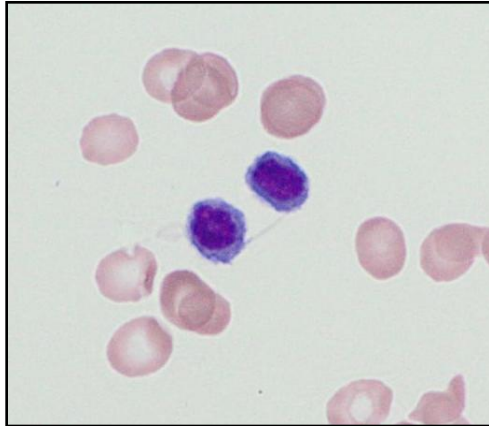
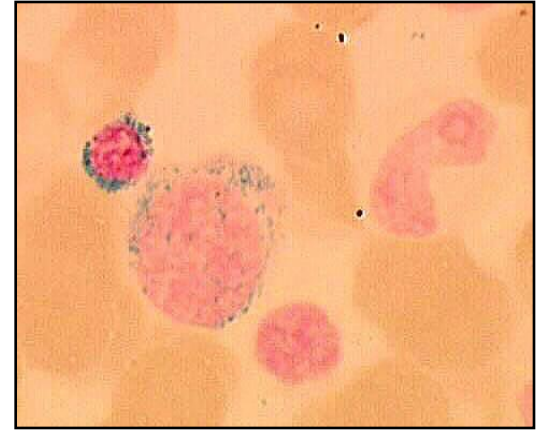
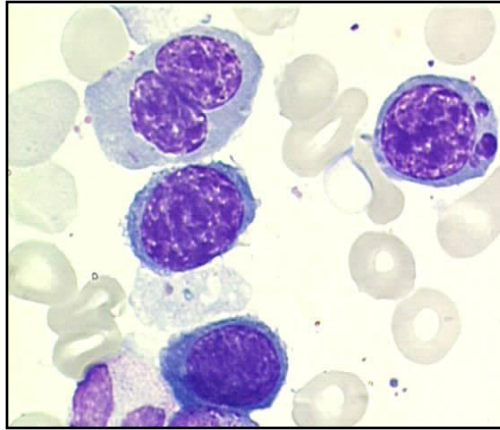
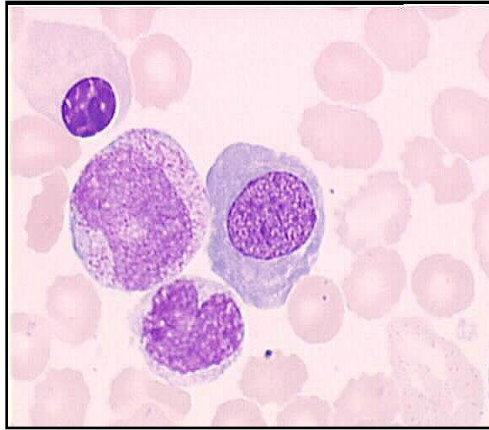

Cytomorphology

- Cytomorphology may be difficult to interpret in the following circumstances:
 - Toxic (drugs, alcoholic, professional exposure, hair color,...)
 - Renal impairment
 - Chronic liver disease
 - B12/Folic acid/Copper deficiencies

Well trained cytomorphologists are mandatory

Diagnosis of MDS in Flow Cytometry

- 1998: Elghetany *et al.*, Haematologica
 - List of all surface antigens (38), on different cell types, that can be modulated in MDS
 - Abnormalities of surface expression
 - => defective cell function
 - => more advanced stage of the disease
 - But there are several pitfalls:
 - Incubation
 - Lysing solutions
 - Fixation
 - Fluorochromes used
 - Antibodies combinations
 - No Methodological consensus

Diagnosis of MDS in Flow Cytometry

First approach: maturational pathway

- 2001: Stelter-Stevenson *et al.*, Blood
 - Dysplasia if more than 2 abnormalities such as:
 - Neutrophils hypogranulation
 - Lack of CD64 expression on granulocytes
 - Discrete blast population (CD45w/SSC population)

• Abnormal
CD11b/CD16 pattern

• Abnormal
CD13/CD16 pattern

- Sensitivity
 - FCM: 88%
 - Morphology: 93%

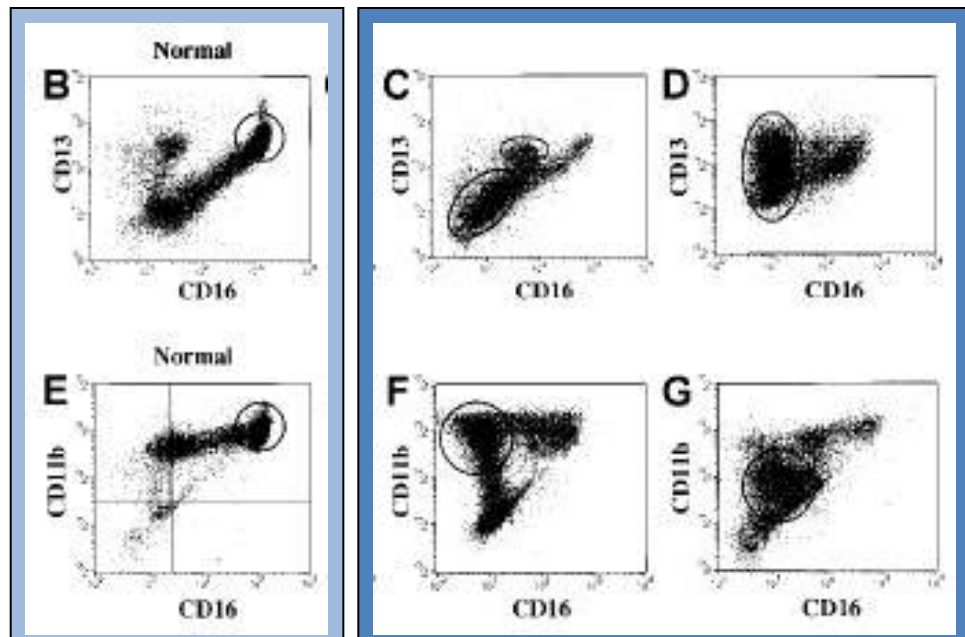

Diagnosis of MDS in Flow Cytometry

First approach: maturational pathway

Normal BM

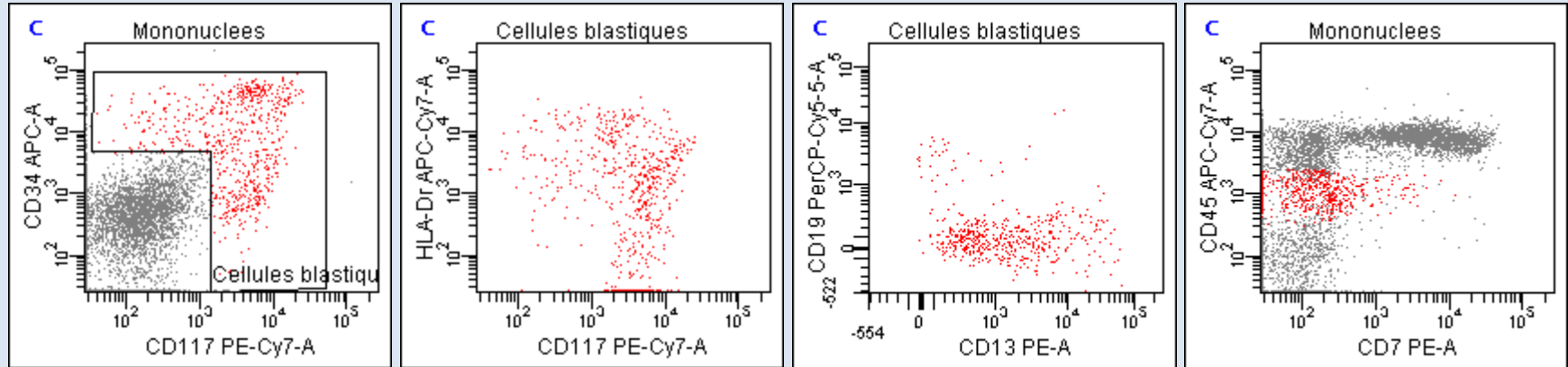

Dysplasia

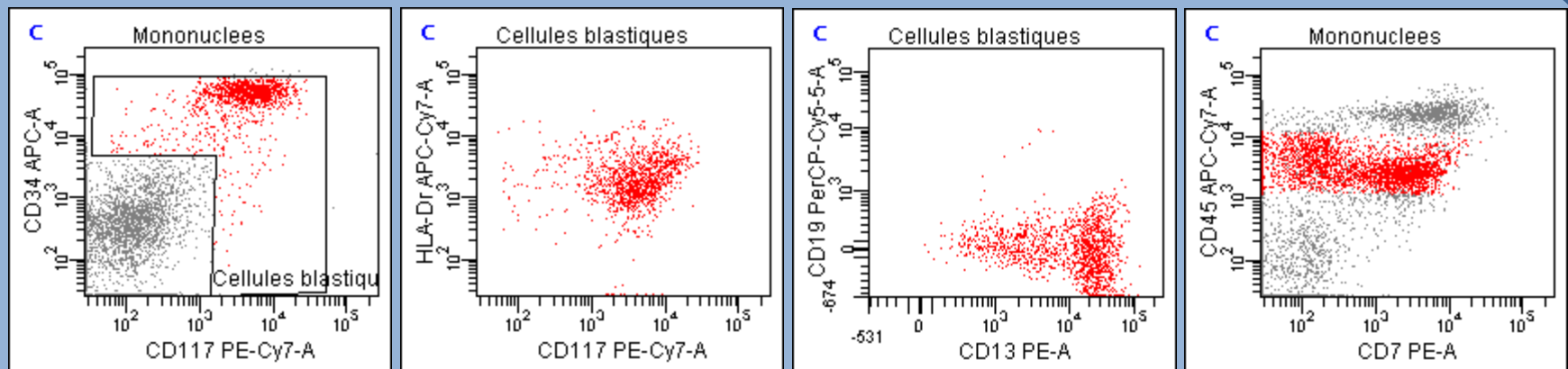

Diagnosis of MDS in Flow Cytometry

First approach: maturational pathway

Normal

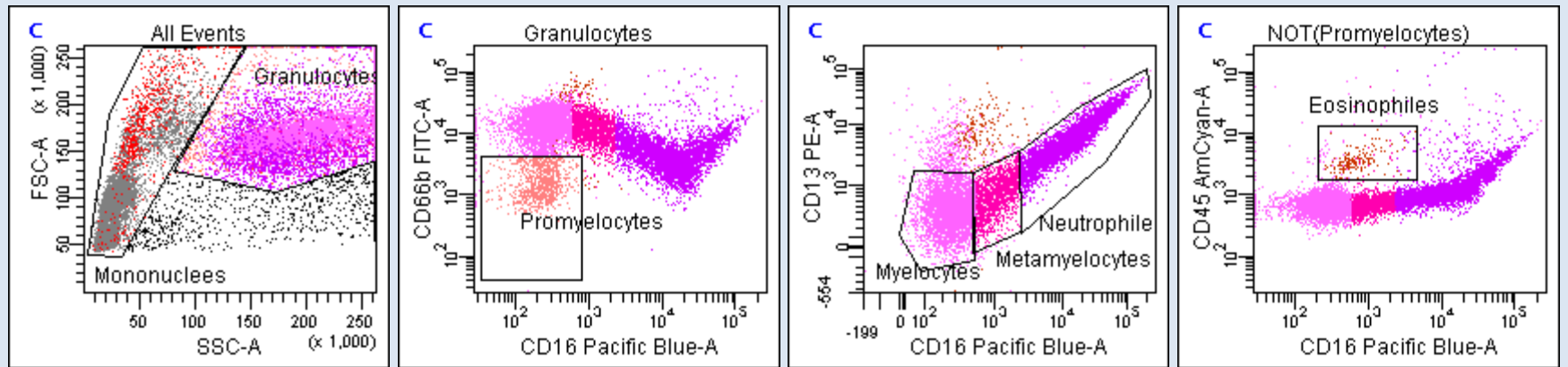

Dysplasia

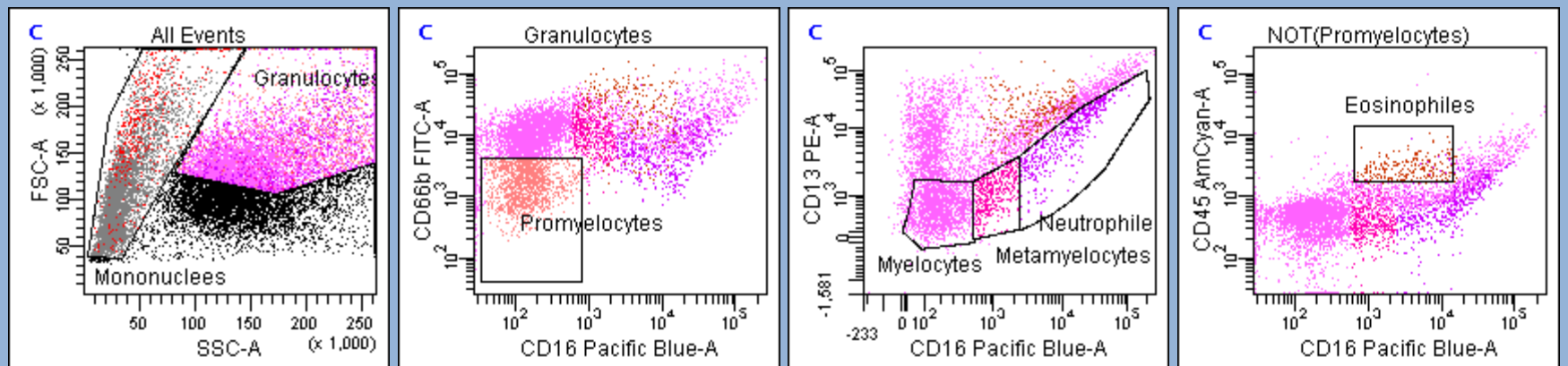

Personal experience

- Retrospective study of 100 BM samples addressed in 2009 for one of the following indication:
 - Anemia, thrombocytopenia, neutropenia (n=37)
 - MDS? (n=52)
 - MPD (n=4)
- Cytomorphologic examination by two trained and blinded cytologists
- Analyse of FCM data by two blinded cytometrists

Personal experience

Cytology	Sensitivity (%)	Specificity (%)
Cytologist 1	88	90
Cytologist 2	90	95
	Agreement	78%

Cytometry	Sensitivity (%)	Specificity (%)
Cytometrist 1	67	80
Cytométrist 2	78	82
	Agreement	78%

Diagnosis of MDS in Flow Cytometry

Second approach: Ogata scoring system

- % of myeloblasts among ANC
- % of B cell precursors among CD34+ cells
- CD45 expression ratio Lymphocytes/blast cells
- Granulocytes/Lymphocytes SSC peak channel ratio

Unaffected by PB contamination

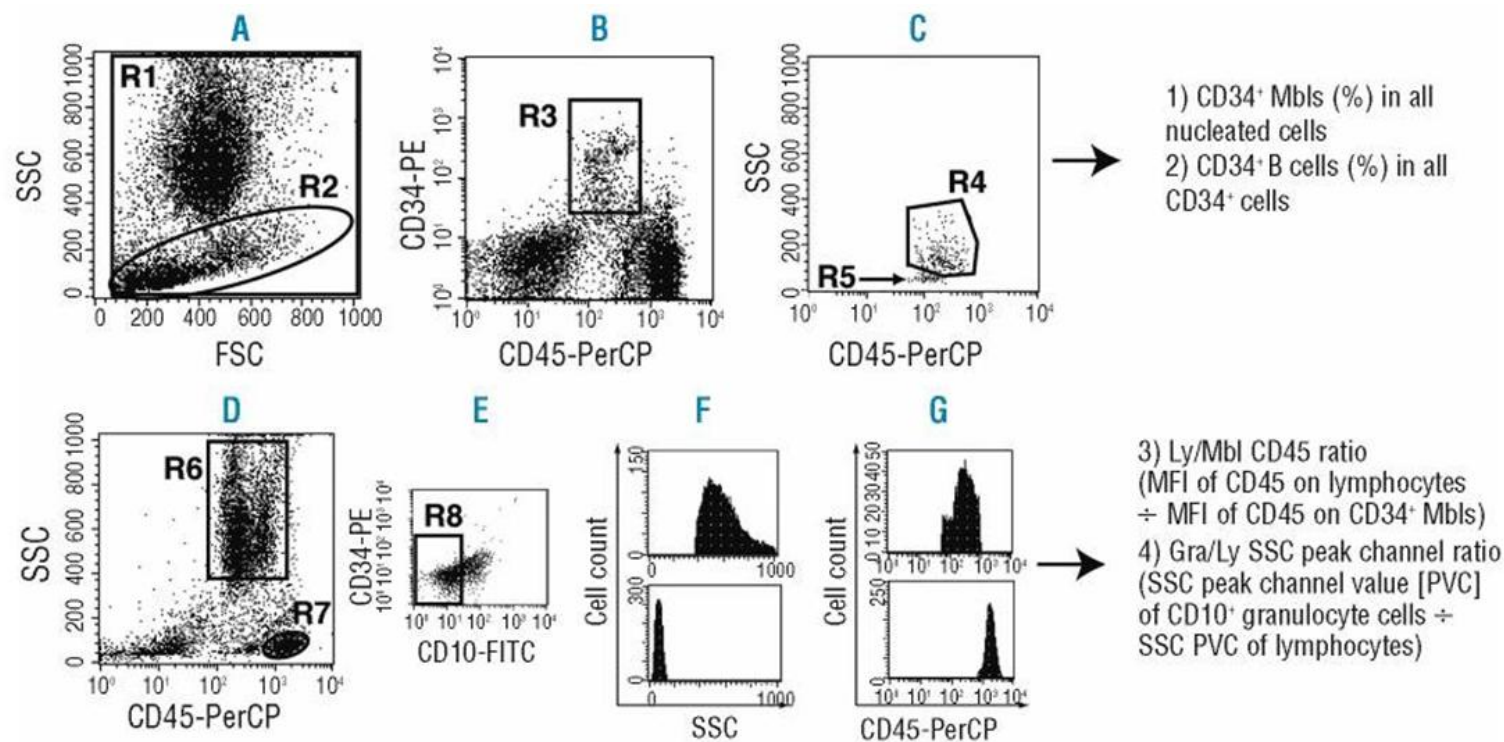

MDS in Flow Cytometry

First conclusions

- Description of several antigens abnormal expression in MDS
 - Abnormal forward/side scatter properties
 - Antigen over expression/down expression (for one cell type at one stage)
 - « Lineage » infidelity: ea CD7, CD56
 - Homogenous antigen expression or maturational arrest
- But
 - None of these abnormal expression is specific for MDS (polymorphism)
 - The more abnormal expression you observed the more likely the MDS is
 - No correlation between abnormal expression and current MDS classification
 - Some abnormal antigen expression may have a prognostic impact

=>We need a standardised method for cell processing, staining and acquisition

=>We need guidelines for the antigens/cells stages to be tested

ELN consensus

- 2009: Standardisation of bone marrow cells processing and handling
 - Bone marrow sample
 - Heparinised sample > EDTA as anticoagulant
 - Room temperature for less than 24h
 - Ammonium chloride (home made or commercial)
 - No cell fixation
 - Lyse-Wash-Stain-Wash
 - Cells staining (500.000 cells/tube for 15min, RT, dark)
 - Minimum 4 colors staining
 - Doublets exclusion by FSCh/FSCa gating
- 2012-2014: Proposal for antigens and cells stages testing
 - Blasts cells (CD45^{low}/SSC^{low}/CD34⁺/HLADr⁺)
 - Progenitor B cells (CD34/CD19/CD10)
 - Maturing mylo-monocytic compartment
 - Erythroid compartment (under investigation)

ELN consensus

<i>Bone marrow subset</i>		<i>Recommended analyses</i>	<i>Aberrancy</i>
Immature myeloid and monocytic progenitors	13	Percentage of cells in nucleated cell fraction ^a Expression of CD45 Expression of CD34 Expression of CD117 Expression of HLA-DR Expression of CD13 and CD33 Asynchronous expression of CD11b, CD15 Expression of CD5, CD7, CD19, CD56 ^b	Increased percentage Lack of/decreased/increased Lack of/decreased/increased Homogenous under/overexpression Lack of/increased expression Lack of/decreased/increased Presence of mature markers Presence of lineage infidelity markers
Progenitor B cells	1	Enumeration as fraction of total CD34+ based on CD45/CD34/SSC in combination with CD10 or CD19	Decreased or absent
Maturing neutrophils	5	Percentage of cells as ratio to lymphocytes SSC as ratio vs SSC of lymphocytes Relationship of CD13 and CD11b Relationship of CD13 and CD16 Relationship of CD15 and CD10	Decreased Decreased Altered pattern ^c Altered pattern ^c Altered pattern ^c ; for example, lack of CD10 on mature neutrophils
Monocytes	6	Percentage of cells Distribution of maturation stages Relationship of HLA-DR and CD11b Relationship of CD36 and CD14 Expression of CD13 and CD33 Expression of CD56 ^b	Decreased/increased Shift towards immature Altered pattern ^c Altered pattern ^c (Homogenous) under/overexpression Presence of lineage infidelity marker
Erythroid compartment ^d	5	Percentage of nucleated erythroid cells Relationship CD71 and CD235a Expression of CD71 Expression of CD36 Percentage of CD117-positive precursors	Increased Altered pattern ^c Decreased Decreased Increased

Personal experience

- Retrospective study of 123 BM samples analysed in 2015 in our center for cytopenia or MDS suspicion
 - **66 non MDS bone marrow samples**
 - Renal anemia: 11
 - B12/folic acid deficiencies: 10
 - ITP: 10
 - Others 35
 - **57 MDS bone marrow samples**
 - MDS-U 4
 - RA (5q- included) 8
 - RCMD 23
 - RAEB 22
- New analysis of FC data for the extraction of 38 numerical values
 - =>22 ELN criteria
 - =>5 new parameters

Blast cells analysis

- Immature myeloid progenitors: CD45^{low}/SSC^{int}/CD34⁺/HLA-Dr⁺

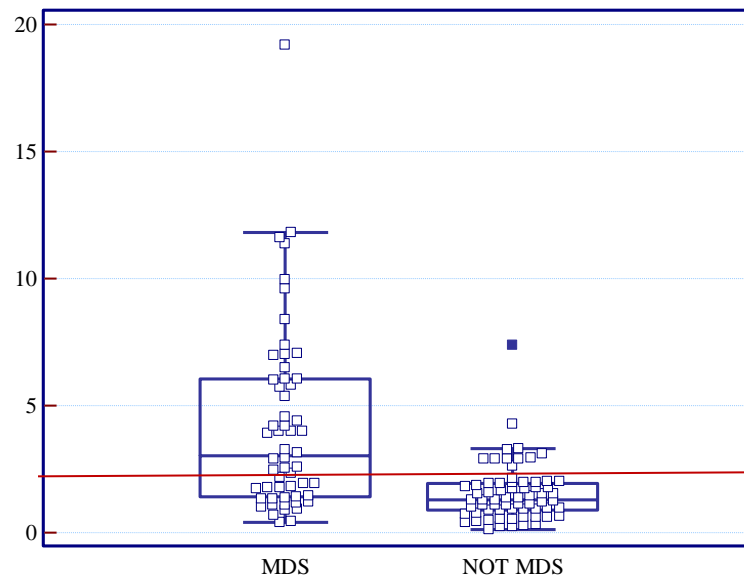
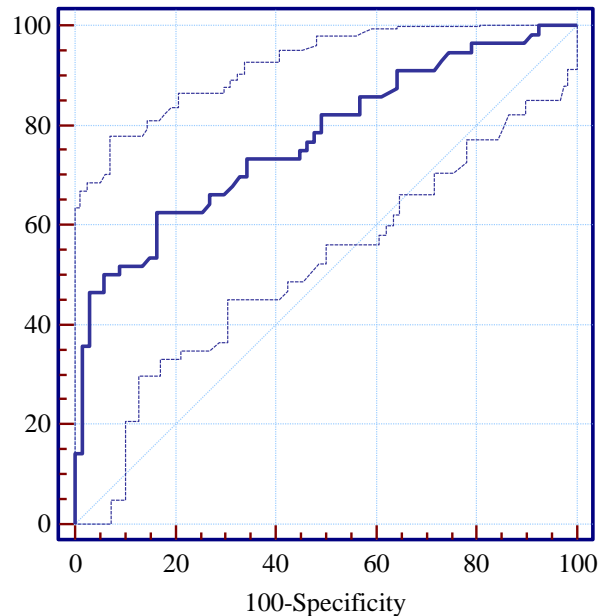
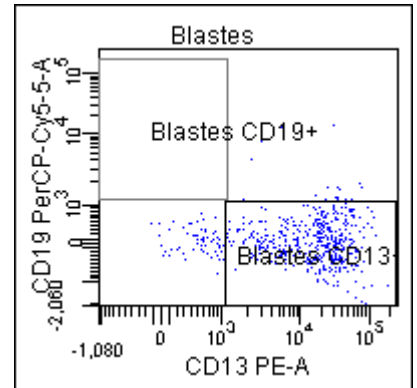
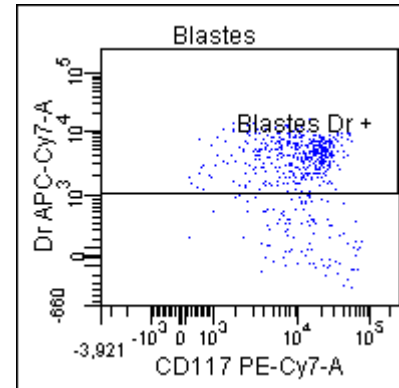
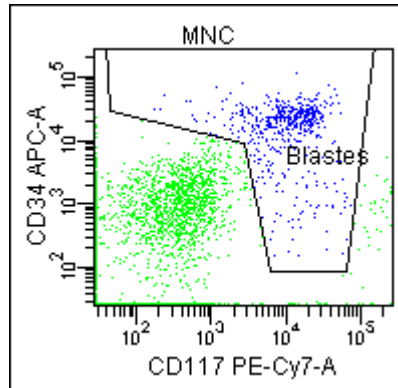
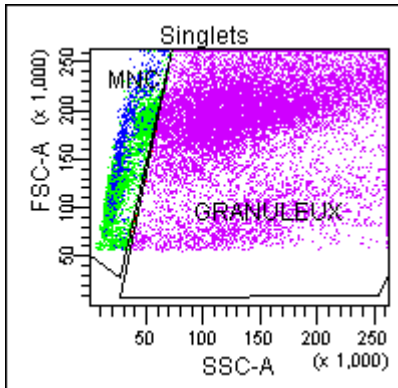

2,13%

Blast cells analysis

ELN	Parameter	Gate	Cut-off	Method	AUC	P value
V	% Myeloblast cells (Mbl)	ANC	>2,13%	ROC	0,77	P<0,0001
	% Blasts (Low CD45)	ANC	>5,21	ROC	0,75	P<0,0001

Immature Myeloid cells
CD45^{low}/SSC^{int}/CD34⁺/HLA-Dr⁺

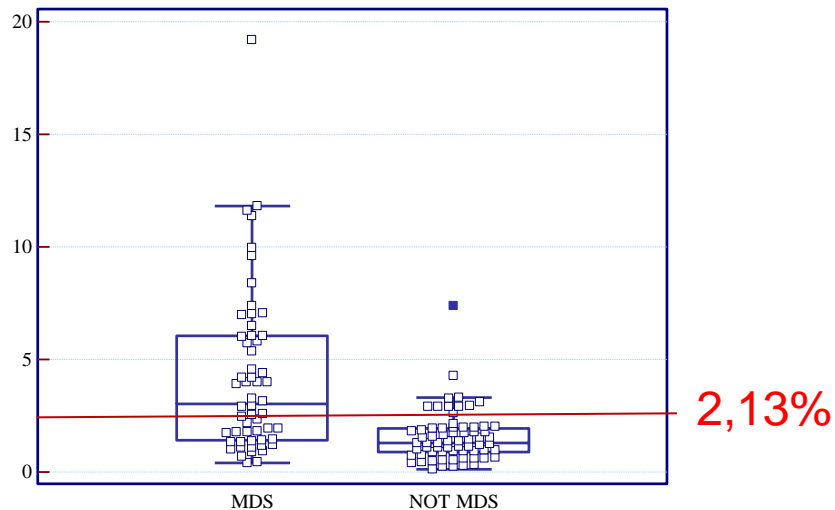

Blasts cells
CD45^{low}/SSC^{int}

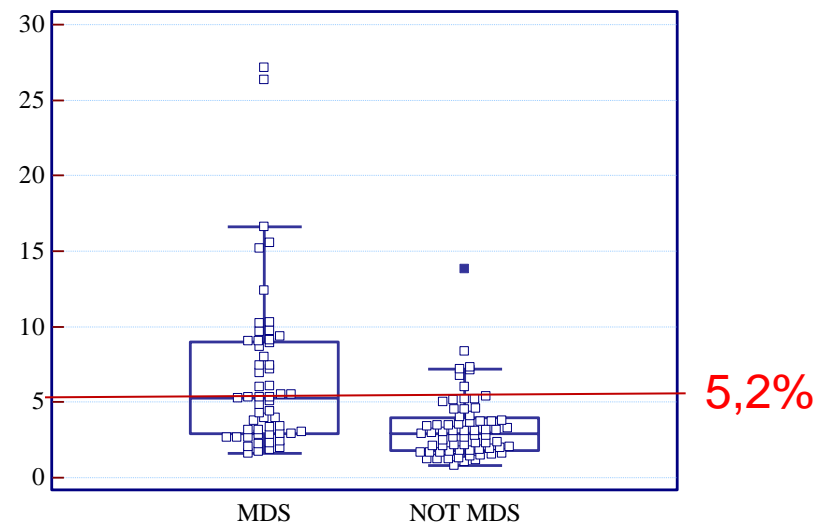

Blast cells analysis

ELN	Parameter	Gate	Cut-off	Method	AUC	P value
V	CD34 MFI	Myeloblasts	>17180	ROC	0,65	P=0,003
V	CD13 MFI	Myeloblasts	>5230	ROC	0,63	P=0,007
V	CD117 MFI	Myeloblasts	>7761	ROC	0,75	P<0,0001
V	HLA-Dr MFI	Myeloblasts	<3056	ROC	0,51	NS (p=0,77)
V	CD45 MFI	Myeloblasts	3800-8100	+/- 2SD	NA	NS (P=0,52)
V	%CD56+	Myeloblasts	>8,6%	ROC	0,5	NS (p=0,28)*
V	%CD7+	Myeloblasts	>10,2%	ROC	0,56	NS (p=0,92)*
V	Ly/Mbl CD45 ratio	/	2,5-7	+/- 2SD	NA	P=0,04

Blast cells analysis

Myeloblasts CD34 MFI

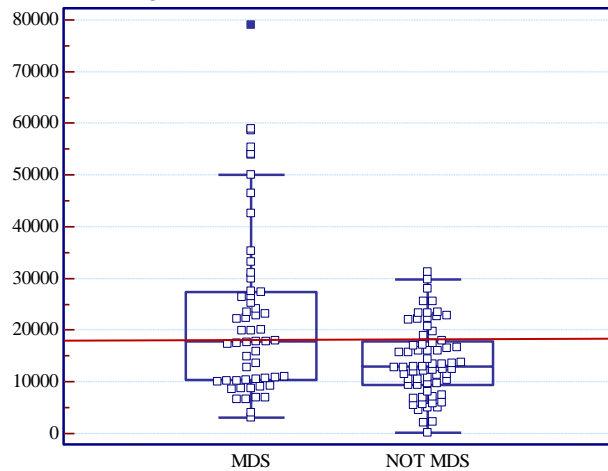

Myeloblasts CD13 MFI

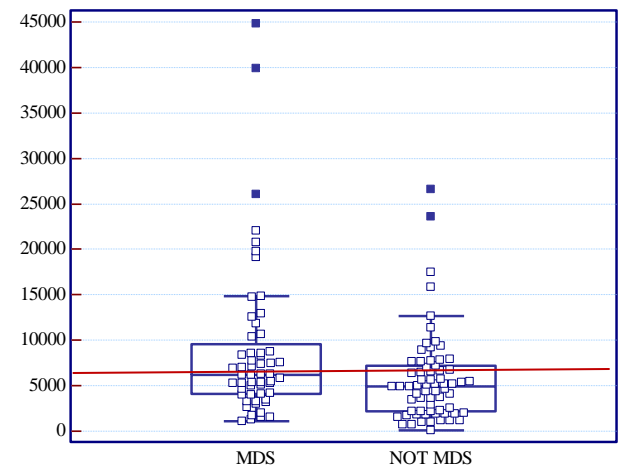

Myeloblasts CD117 MFI

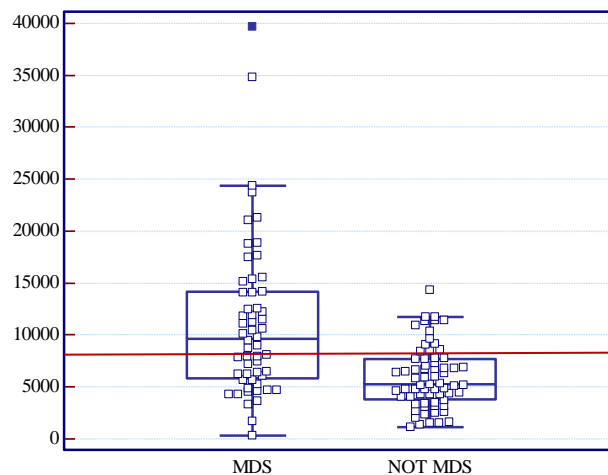

Myeloblasts HLA-Dr MFI

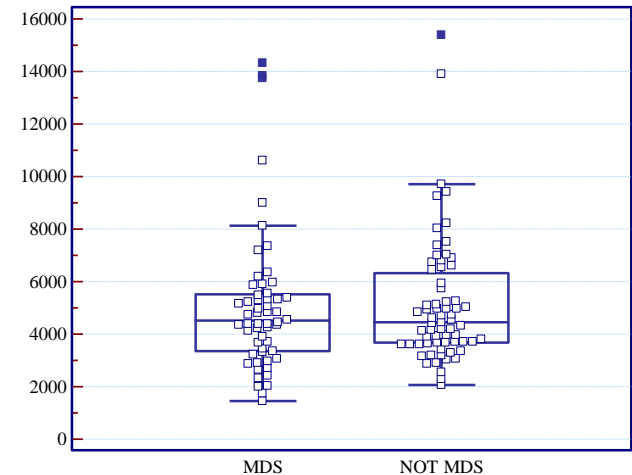

Blast cells analysis

Lymphocytes CD45 MFI/Myeloblasts CD45 MFI

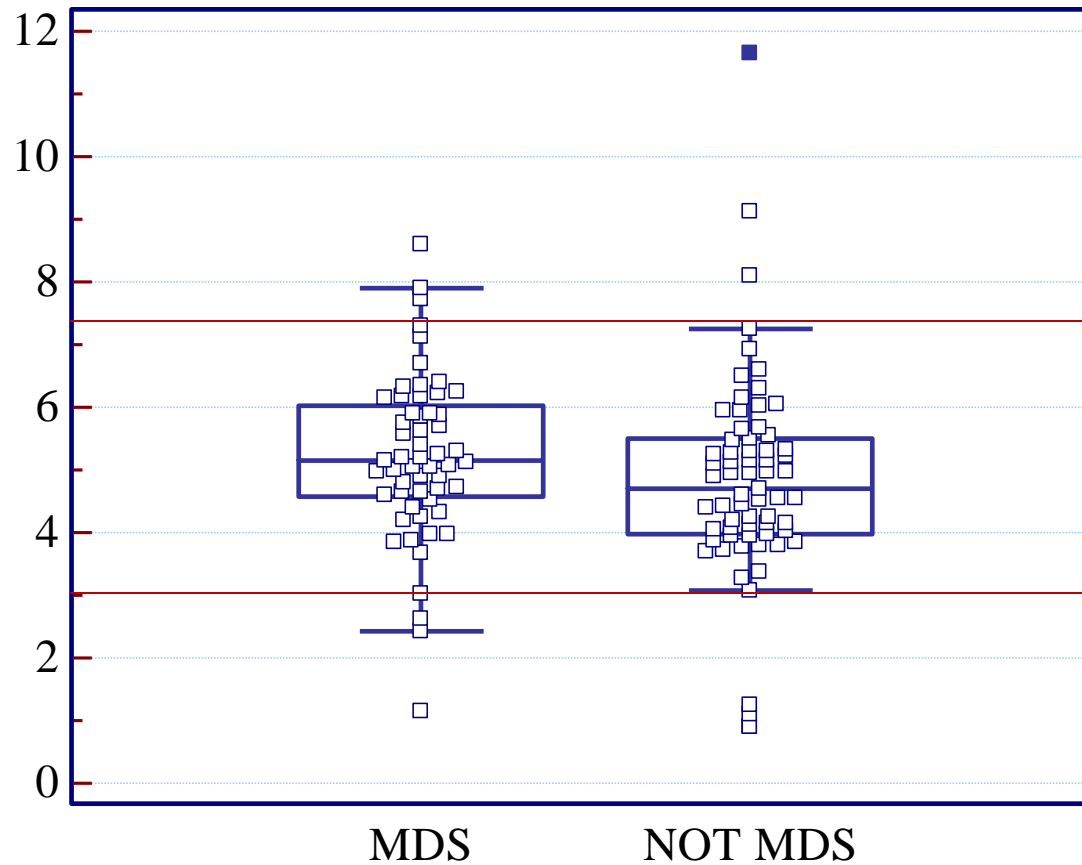

Immature B Cells

ELN	Parameter	Gate	Cut-off	Method	AUC	P value
V	% CD10+ B Ly	ANC	<0,071%	ROC	0,61	P=0,03
	% CD19+ CD34+	ANC	<0,04%	ROC	0,60	NS (P=0,06)
V	CD19+CD34+/Mbl ratio	/	<4,78%	ROC	0,75	P<0,0001
	CD10+ B Ly/Mbl ratio	/	<16,57	ROC	0,75	P<0,0001

% CD34+ CD19+ / %Mybl

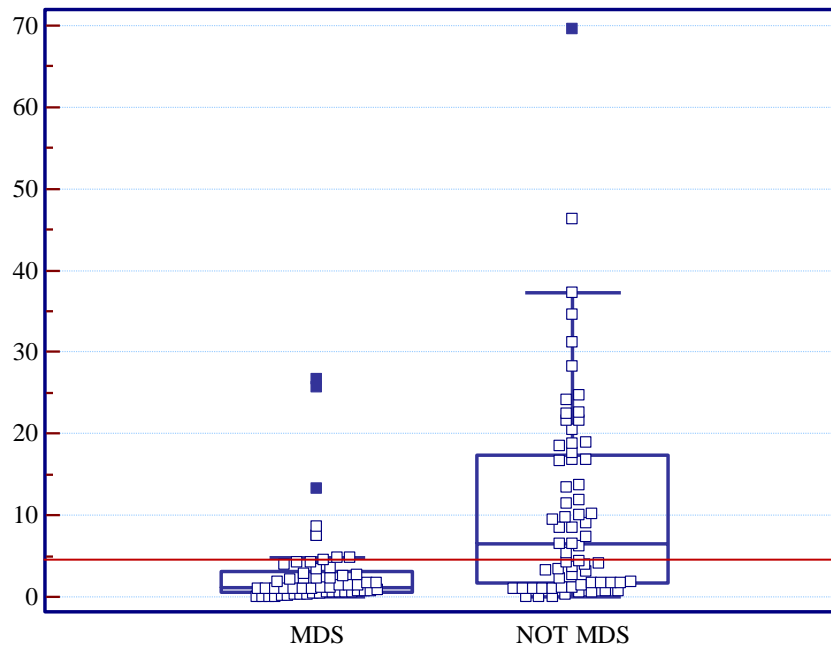

% CD19+ CD10+ / %Mybl

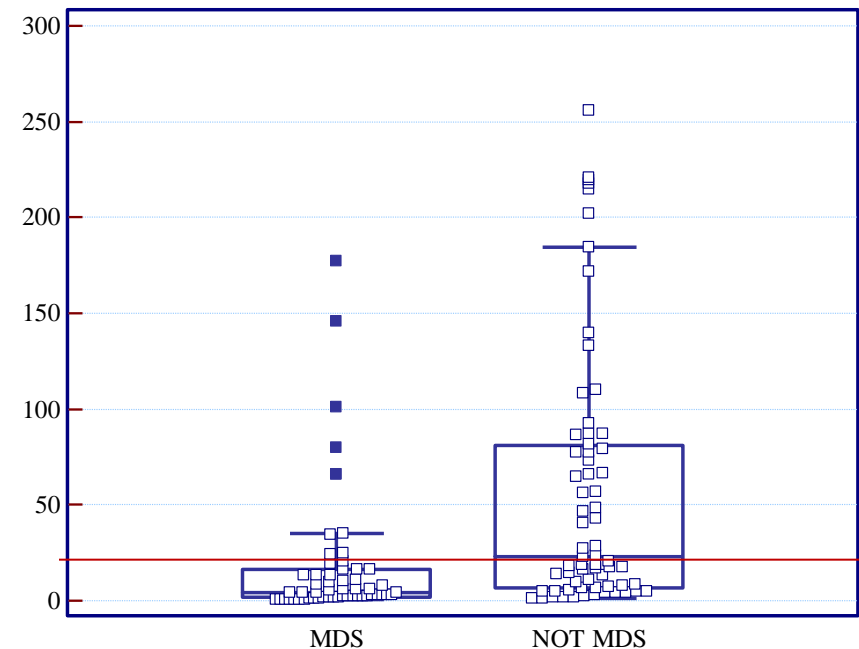

Monocytic lineage

ELN	Parameter	Gate	Cut-off	Method	AUC	P value
V	% Monocytes	ANC	>2,78%	ROC	0,57	NS (p=0,18)
V	% CD56 +	Monocytes	>8,1%	ROC	0,62	P=0,02
V	CD11c MFI	Monocytes	<12041	ROC	0,61	P=0,022
V	CD14 MFI	Monocytes	<4575	ROC	0,64	P=0,005
V	CD36 MFI	Monocytes	<27470	ROC	0,63	P=0,006
	HLA-Dr MFI	Monocytes	<1388	ROC	0,59	NS (p=0,1)

CD14 MFI

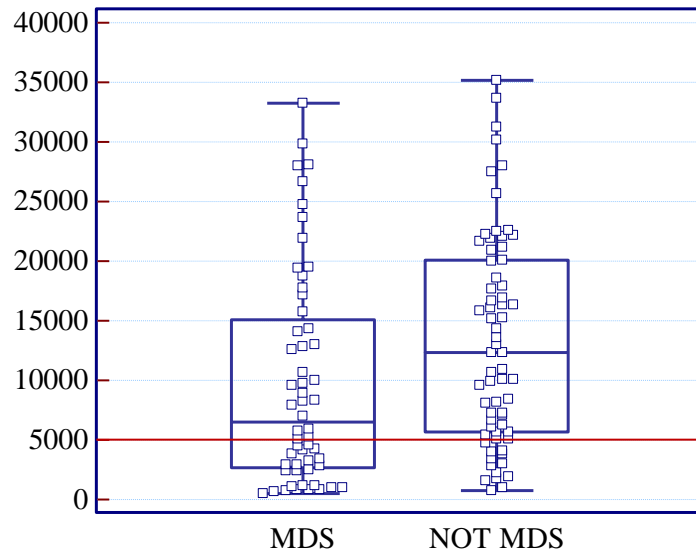

CD36 MFI

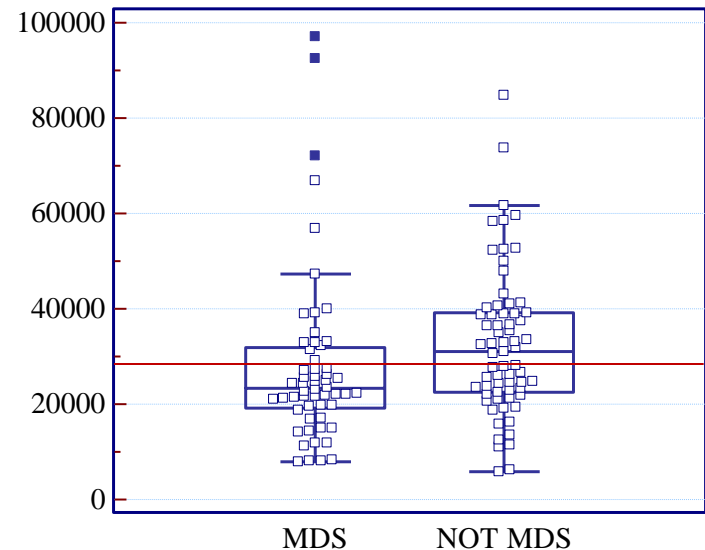

Erythroid lineage

ELN	Parameter	Gate	Cut-off	Method	AUC	P value
V	CD36+CD117+ Erythroid cells	ANC	>4,8%	ROC	0,63	P=0,009
V	CD36 MFI	Erythroblasts	<21025	ROC	0,65	P=0,003
V	CD71 MFI	Erythroblasts	<104097	ROC	0,55	P=0,32
V	CD36 CV	Erythroblasts	>50,93	ROC	0,71	P=0,0001
V	CD71 CV	Erythroblasts	>48,6	ROC	0,68	P=0,0002

MDS

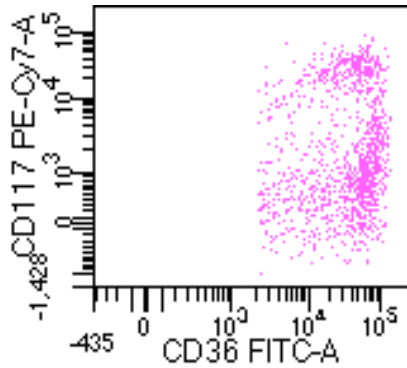

Not MDS

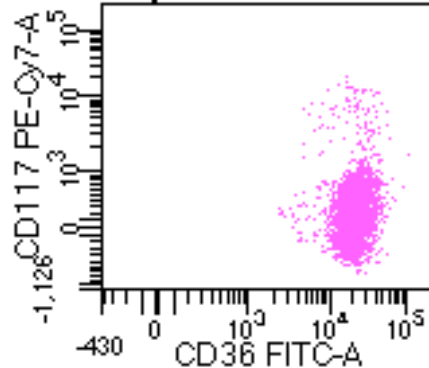

CD36 MFI CV

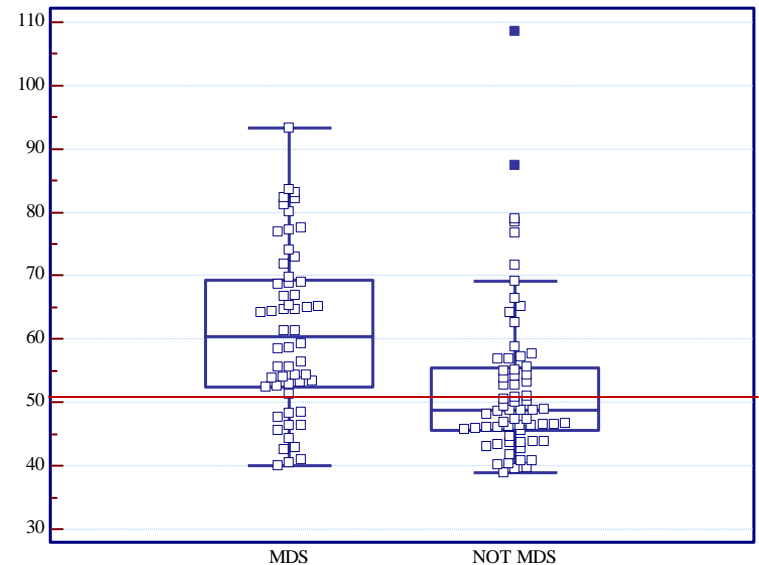

Conclusion

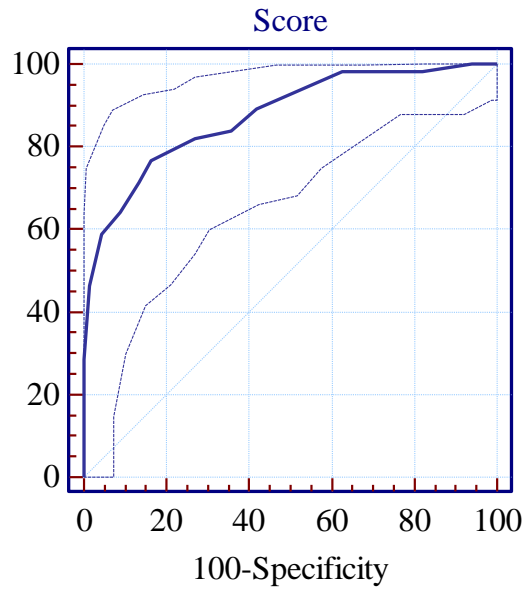

AUC: 0,88%

Sensitivity: 77%

Specificity: 84%

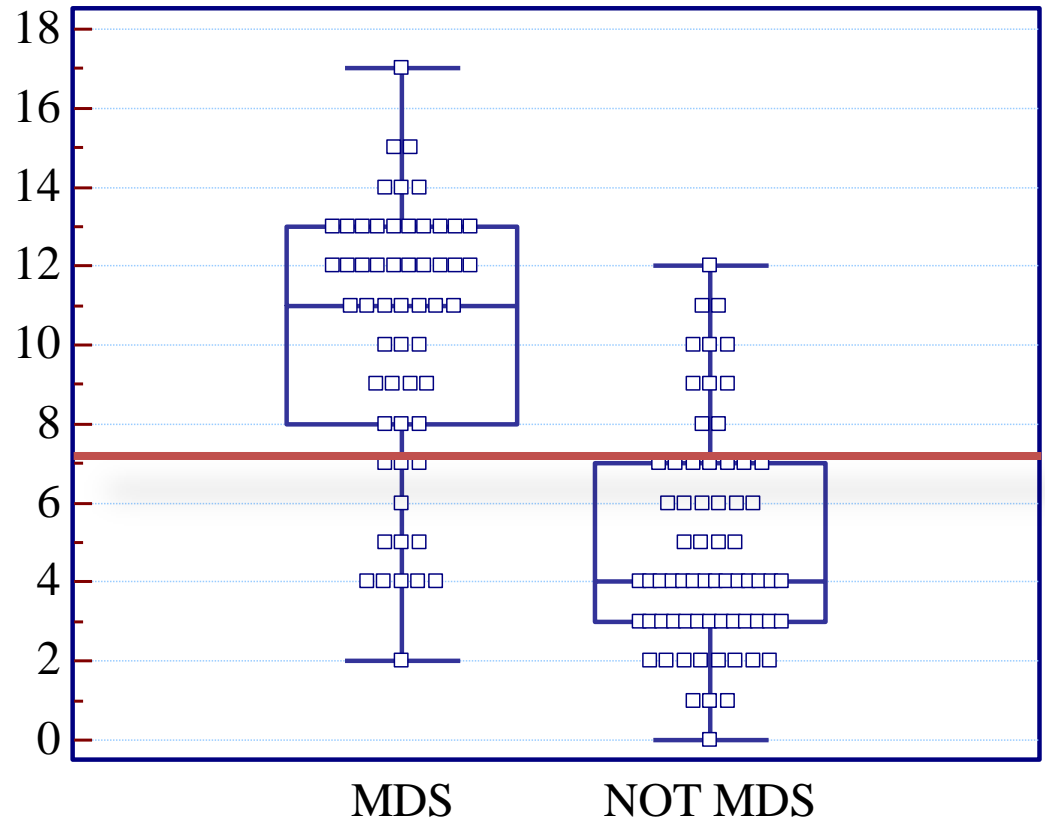

Conclusion

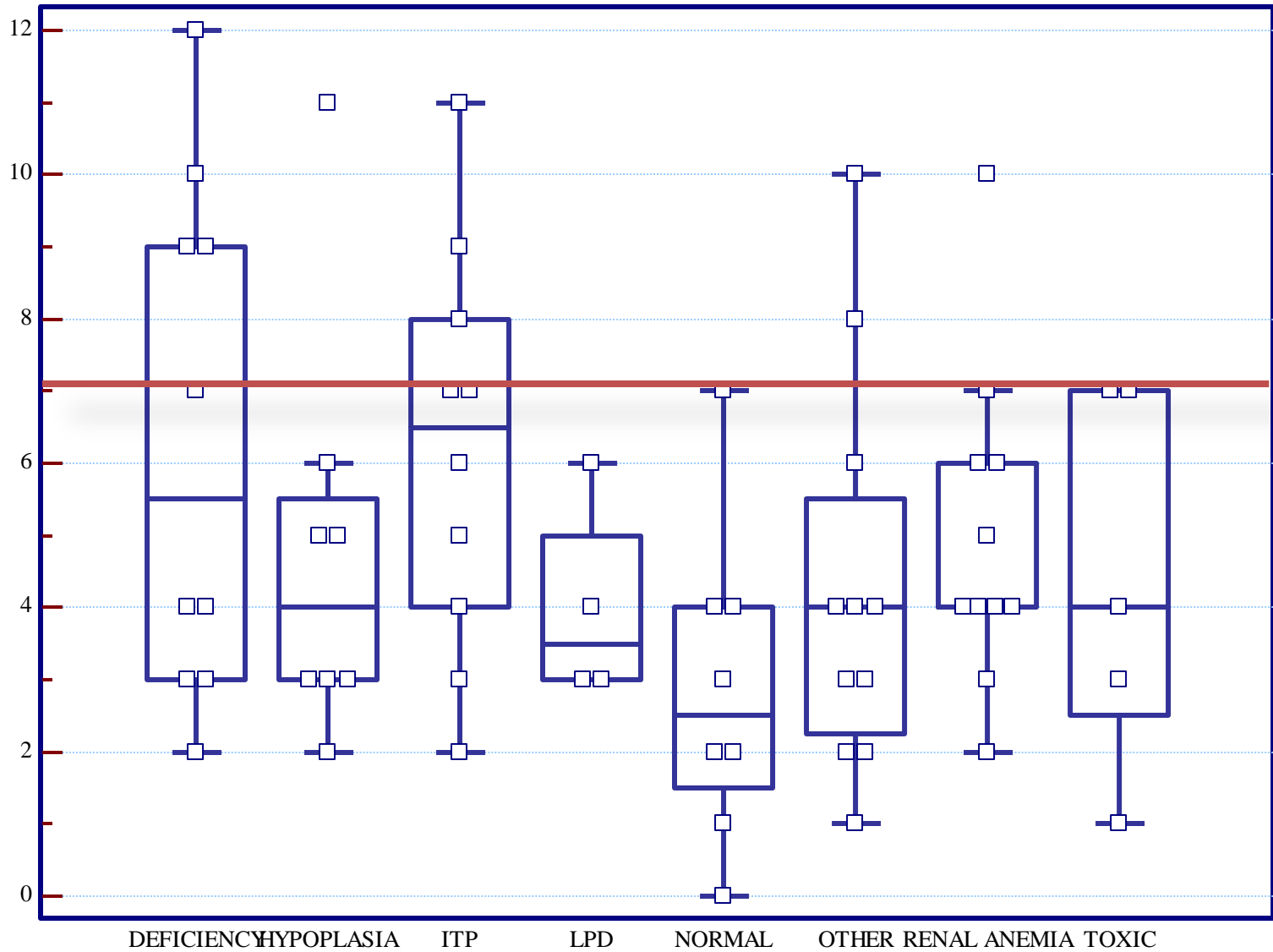

Conclusion

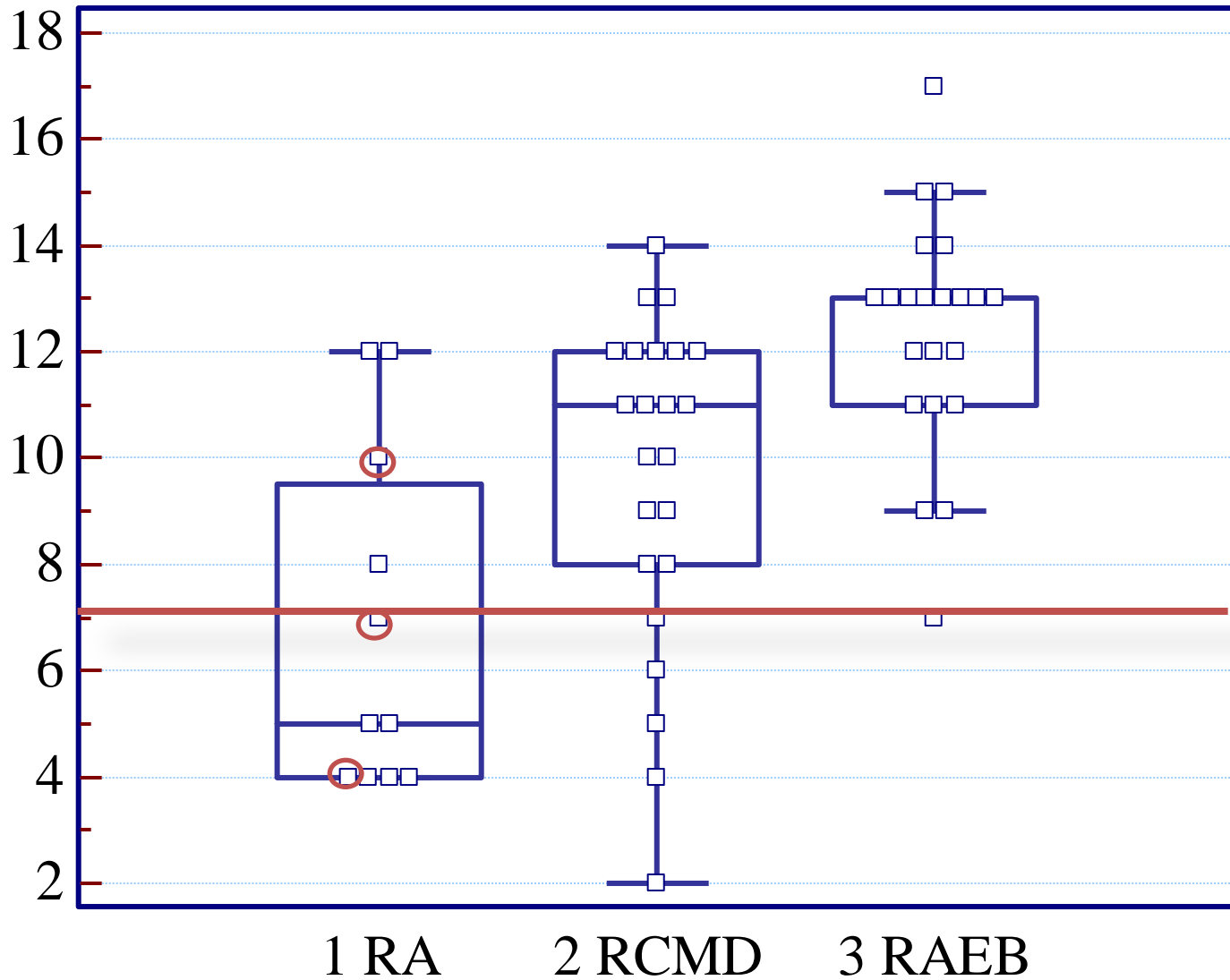

Conclusion

- FCM should be part of the integrated MDS diagnosis work up
- MDS diagnosis requires controlled preanalytical conditions (anticoagulant, time to processing, storage, lysing, washing, fixative agents, staining protocols, antibodies, fluorochromes, cytometer settings...)
- Useful parameters :
 - Immature Myeloid cells (CD45/CD34/CD117/HLA-Dr)
 - Immature Myeloid cells phenotype
 - Homogenous
 - CD34, CD117, CD13, CD7, CD56, (CD45?)
 - Immature B cells/immature myeloid cells ratio
 - Granulocytes maturation
 - Hypogranulation (SSC)
 - CD11b/CD16 maturation pathway
 - CD13/CD16 maturation pathway
 - Erythroid cells
 - CD36 CV%
 - CD36 MFI
- Discuss with your cytomorphologist

Pitfalls in flow cytometry:

- Peripheral blood contamination
- Contamination of the population of interest (basophils, eosinophils, ...)
- Inter-individuals polymorphism (CD33, CD16)
- G-CSF therapy, infection, inflammation (CD56, HLA-Dr)
- Apoptosis (CD16)
- PNH Clones: Loss of GPI anchored proteins (CD16, CD14, CD66b, CD55, CD59)
- Population count (low monocytes or blast cell count)
- Monocytes adhering to T-cell or platelets